

# ICC-ES Evaluation Report

**ESR-4900**

Reissued June 2025

Revised December 2025

Subject to renewal June 2026

ICC-ES Evaluation Reports are not to be construed as representing aesthetics or any other attributes not specifically addressed, nor are they to be construed as an endorsement of the subject of the report or a recommendation for its use. There is no warranty by ICC Evaluation Service, LLC, express or implied, as to any finding or other matter in this report, or as to any product covered by the report.

Copyright © 2025 ICC Evaluation Service, LLC. All rights reserved.

<p><b>DIVISION: 31 00 00 – EARTHWORK</b></p> <p><b>Section: 31 60 00 – Special Foundations and Load-Bearing Elements</b></p>	<p><b>REPORT HOLDER:</b></p> <p><b>EVERSTRONG STRUCTURES CORP</b></p>	<p><b>EVALUATION SUBJECT:</b></p> <p><b>ORIGINAL EVERJACK AND ALL-IN-1 EVERJACK</b></p>	
------------------------------------------------------------------------------------------------------------------------------	-----------------------------------------------------------------------	-----------------------------------------------------------------------------------------	-------------------------------------------------------------------------------------

## 1.0 EVALUATION SCOPE

**Compliance with the following codes:**

- 2024, 2021 and 2018 [International Building Code® \(IBC\)](#)
- 2024, 2021 and 2018 [International Residential Code® \(IRC\)](#)

**Properties evaluated:**

- Structural
- Low Temperature Durability

## 2.0 USES

The Original EverJack and All-in-1 EverJack (referred to collectively hereafter as EverJack products or EverJacks) are used in under-floor spaces, such as crawl spaces, in buildings of Type V construction under the IBC or any construction under the IRC. The Original EverJack is used as individual, isolated footings supporting post columns for downward vertical loads only. The All-in-1 EverJack product serves the same purpose as the Original EverJack, except that it provides an increased adjustable height range through a molded extender adapter assembly, thereby eliminating the need for intermediate wood posts.

## 3.0 DESCRIPTION

The Original EverJack is a molded composite footing assembly comprised of components formed by an injection molding process. The EverJack components include a base, cap bolt and boot disc. The base and cap bolt components are manufactured from a proprietary composite of polypropylene and fiber reinforcement, and the boot disc component is manufactured from ABS plastic.

The base component is a circular, ribbed pad with an internally threaded cylindrical shaft which extends vertically from the center of the base. The cap bolt component has a cylindrical, externally threaded shaft and a circular top cap plate. The cap bolt threads into the EverJack base, allowing for adjustability of the cap bolt height through rotation of the cap bolt. The boot disc component is a circular disc with interior flanges arranged in a square shape. The boot disc fits atop the cap bolt component. See [Figure 2](#) for details of the EverJack assembly configuration. See [Figures 3](#) and [4](#) for dimensions of the EverJack base, cap bolt and boot disc components, respectively.

The All-in-1 EverJack is manufactured from the same proprietary composite of polypropylene and fiber reinforcement. The assembly (see [Figure 5](#)) consists of the same molded base as the Original EverJack and an extender adapter assembly, which includes four molded components: cap bolt adapter, hex shaft extender, rotating plate, and clip bracket. The hex-shaft extender threads into the base component at the bottom and onto the cap-bolt adapter at the top. The rotating plate is installed to the top of the extender to facilitate angular adjustment. Clip

brackets are attached to the raised tabs of the rotating plate to secure the supported wood beam. See Figures through [9](#) for components dimensions.

## 4.0 DESIGN AND INSTALLATION

### 4.1 Design:

The EverJack base is designed as surface rigid footings that uniformly transmits the applied downward vertical load to the supporting soil or concrete foundation material. For the Original EverJack, these loads are imposed by a nominal 4x4 [3.5 by 3.5 inches (89 by 89 mm)] wood post that supports subsequently the wood flooring system of the under-floor spaces. The base of the post is supported by the top cap of the EverJack cap bolt and is centered on the top cap with the EverJack boot disc. The load is transferred from the post, through the EverJack cap bolt, into the EverJack base, and distributed on the ground surface.

The All-in-1 EverJack supports the wood flooring system directly through a bracket connection, applied downward vertical loads are transferred through the extender adapter assembly threaded into the base and distributed to the ground surface. The system is designed to accommodate wood beams with nominal widths ranging from 3.5 inches to 4.5 inches.

Allowable loads are controlled by the type of supporting soil or capacity of foundational materials, as applicable. The EverJacks design load must not exceed the allowable downward vertical loads shown in [Table 1](#).

### 4.2 Installation:

Installation of the EverJack products must be in accordance with this report, the applicable code and the report holder's published installation instructions.

The EverJack products must be installed at grade level, on soil or concrete, in underfloor spaces, such as crawl spaces. Before placement, the ground surface must be made uniform as described in the report holder's installation instructions to ensure direct, uniform, level bearing of the EverJack products on the supporting soil or foundation material, as applicable.

#### 4.2.1 For the Original EverJack

Boot disc must be placed in the top cap of the cap bolt. The cap bolt is then raised as described in the report holder's installation instructions to receive the base of the wood post. The wood post must have a solid base which bears uniformly on the top cap of the EverJack cap bolt. The post base must be centered on the top cap using the boot disc. The final height the cap bolt must be such that the thread engagement between the cap bolt and EverJack base is not less than 2.5 inches (63.5 mm). See [Figure 1](#) for a typical installation example detail.

#### 4.2.2 For the All-in-1 EverJack

Each threaded interface (base to extender and extender to cap-bolt) must maintain enough thread engagement as shown in Figure 5. Installation shall follow the manufacturer's instructions and the same environmental limitations as the Original EverJack. The wood beam must bear uniformly on top of the EverJack Hex shaft extender. The beams width must be centered on the Hex shaft Extender using the clip brackets.

## 5.0 CONDITIONS OF USE:

The EverJack products described in this report comply with, or are suitable alternatives to what is specified in, those codes listed in Section 1.0 of this report, subject to the following conditions:

- 5.1 Installation must be in accordance with this report and the report holder's published installation instructions. In the case of a conflict between the published installation instructions and this report, the more restrictive requirements govern.
- 5.2 The Original EverJack and the All-in-1 EverJack are used to support wood posts and wood beams, respectively, under-floor spaces for Type V construction under the IBC or any construction under the IRC.
- 5.3 For installations in under-floor spaces such as crawl spaces in compliance with the IBC and IRC, the bottom of interior footings are permitted to be installed at finished grade unless otherwise required by IBC Section 1809.5 or IRC Section R403.1.4.1 for frost protection or by IBC Section 1805.1.2 or IRC Section R408.6 for surface or ground-water. Installation of the EverJack products below finished grade is outside of the scope of this report.
- 5.4 The EverJack products may be installed directly on top of concrete foundational materials in crawl spaces provided the following:

- 5.4.1** The concrete foundational materials must be designed for the applicable loads, including the load transferred from the EverJack products, subject to approval by the building official.
- 5.4.2** Where the crawl space is subject to below freezing temperatures, concrete foundational materials must be protected from frost in accordance with IBC Section 1809.5 or IRC Section R403.1.4.1, subject to approval by the building official.
- 5.4.3** Design and installation of concrete foundational materials are outside the scope of this report and are subject to approval by the building official.
- 5.5** The EverJack products must not be stored or installed where subject to UV exposure.
- 5.6** The EverJack products must not be installed in under-floor spaces subject to temperatures below -20°F (-29°C) or above 104°F (40°C).
- 5.7** The design of the structure (including the wood post and wood beams) supported by the EverJacks is outside the scope of this report.
- 5.8** Design calculations in accordance with Chapter 18 of the IBC, Chapter 4 of the IRC must be submitted to the code official. The design must take into consideration the spacing of the EverJacks.
- 5.9** The EverJacks are manufactured under a quality control program with inspections by ICC-ES.
- 5.10** Both Original EverJack and All-in-1 EverJack are limited to use as individual isolated footings supporting downward compression loads only, in accordance with AC49 Section 1.2.
- 5.11** The All-in-1 EverJack must not be stacked with more than one extender adapter; multiple adapters are outside the scope of this report. Extension of the adapter must not exceed the values provided in Figure 5.

## 6.0 EVIDENCE SUBMITTED

- 6.1** Reports of testing addressing vertical load capacity in accordance with Sections 4.4 and 4.5 of the [ICC-ES Acceptance Criteria for Molded Plastic Footing Pads \(AC49\)](#), dated May 2025.
- 6.2** Reports of testing addressing low temperature durability (low temperature effects, freeze/thaw resistance).

## 7.0 IDENTIFICATION

- 7.1** The ICC-ES mark of conformity, electronic labeling, or the evaluation report number (ICC-ES ESR-4900) along with the name, registered trademark, or registered logo of the report holder (EverStrong Structures Corp) must be included in the product label.
- 7.2** In addition, the EverJacks are identified with a label including the product name and date of manufacture.
- 7.3** The report holder's contact information is the following:

**EVERSTRONG STRUCTURES CORP**  
13681 NEWPORT AVE #8-386  
TUSTIN, CALIFORNIA 92780  
(562) 283-5909  
[www.ever-jack.com](http://www.ever-jack.com)

**TABLE 1—EVERJACK PRODUCTS ALLOWABLE LOADS RELATED TO LOAD-BEARING PRESSURES OF SOILS OR FOUNDATION MATERIALS**

CONFIGURATION	SOIL AND FOUNDATION ALLOWABLE BEARING PRESSURE <sup>1</sup> (psf)	BEARING AREA (ft <sup>2</sup> )	MAXIMUM EXTENSION (in.)	MINIMUM THREAD ENGAGEMENT(in.)	SOIL BEARING CAPACITY (lbf)	ULTIMATE TEST LOAD CAPACITY <sup>4</sup> (lbf)	FACTOR OF SAFETY	ALLOWABLE CAPACITY (lbf)
ORIGINAL EVERJACK	12,000 <sup>2</sup>	2.0	2.5	2.5	24,000	25,200 <sup>4a</sup>	3.0	8,400
ALL-IN-1 EVERJACK			See Figure 5 (5.0 at Hex-Extender and 2.0 at Base)	See Figure 5 (6.0 at Hex-Extender and 3.0 at Base)				
ORIGINAL EVERJACK	1,500 <sup>3</sup>	2.0	2.5	2.5	3,000	N/A <sup>5b</sup>	N/A	3,000
ALL-IN-1 EVERJACK			See Figure 5 (5.0 at Hex-Extender and 2.0 at Base)	See Figure 5 (6.0 at Hex-Extender and 3.0 at Base)				

For SI: 1 inch = 25.4 mm; 1 lbf = 4.4 N; 1 lbf/ft<sup>2</sup> = 47.9 Pa.

1. Load-bearing pressures of soils shall be determined using the presumptive load-bearing values in IBC Table 1806.2 or IRC R401.4.1, as applicable, or the load-bearing values shall be determined with a site-specific soil investigation, as required by the code official.
2. A bearing pressure of 12,000 psf represents extremely stiff soil like crystalline bedrock and concrete foundations. Concrete elements used as foundations must be designed by a registered design professional for the applicable loads, and the load bearing pressure of the soil supporting the concrete elements must not be exceeded. Design and installation of concrete foundation materials are outside the scope of this report.
3. For the sake of this Table, a bearing pressure of 1,500 psf includes: Class 2. Sedimentary and foliated rock, Class 3. Sandy Gravel and/or Gravel (GW/GP), Class 4. Sand, Silty Sand, Clayey Sand, Silty Gravel, and Clayey Gravel (SW, SP, SM, SC, GM, and GC), Class 5. Clay, Sandy Clay, Silty Clay, Clayey Silt, Silt, and Sandy Silt (CL, ML, MH, and CH).
4. Per AC49, the allowable capacity for the EverJack system is taken as the lesser of: the soil and foundation allowable bearing pressure; the ultimate test load divided by a safety factor of three; and the load at which a 0.75-inch deflection occurs at the point of load application (total deflection). Creep test at 2000 hours were also completed per AC49.
  - a. For the test in 12,000 psf soil, the ultimate test load divided by a safety factor of three governed due to the capacity of the EverJack.
  - b. For the test in 1,500 psf soil, the soil and foundation allowable bearing pressure governed.
  - c. A load at which a 0.75-inch deflection occurs did not govern in any of the tests completed.

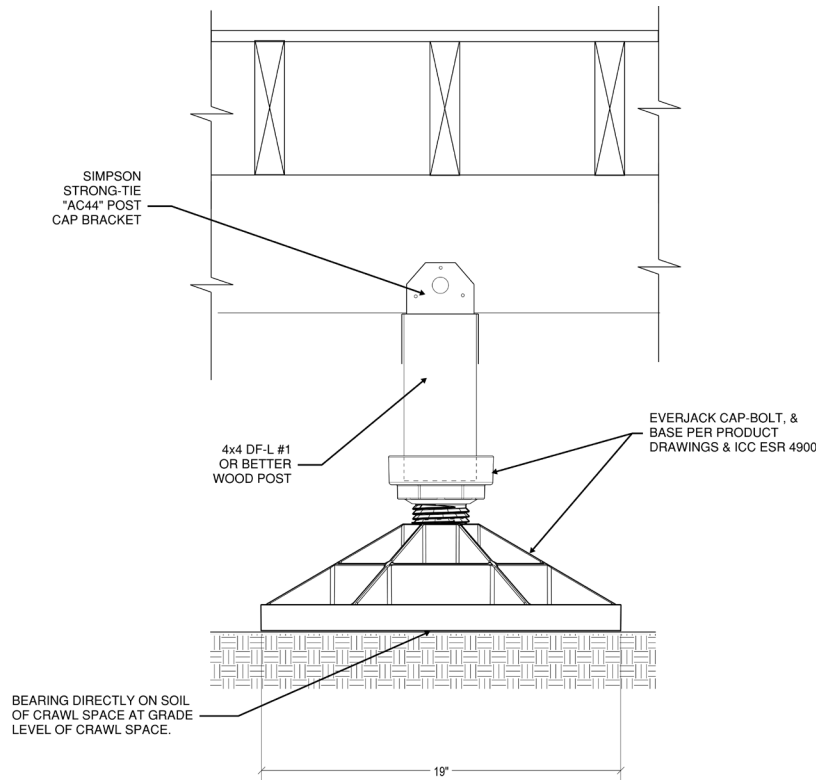

**FIGURE 1—ORIGINAL EVERJACK TYPICAL INSTALLATION EXAMPLE**



FIGURE 2—ORIGINAL EVERJACK ASSEMBLY

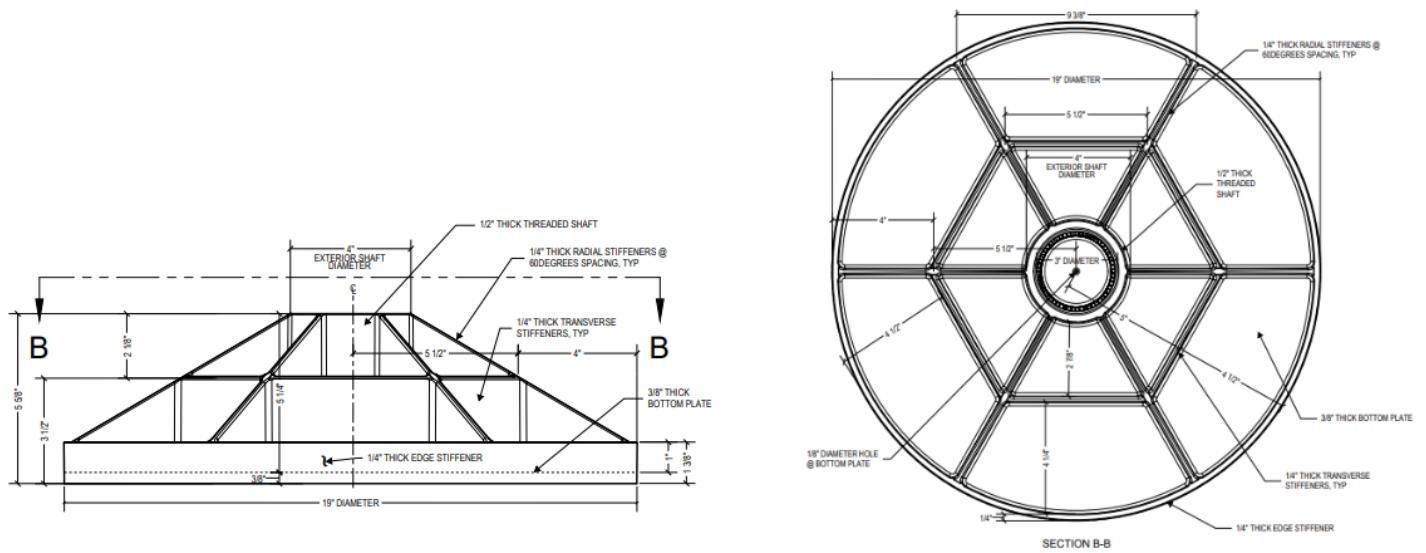

FIGURE 3—ORIGINAL EVERJACK BASE COMPONENT

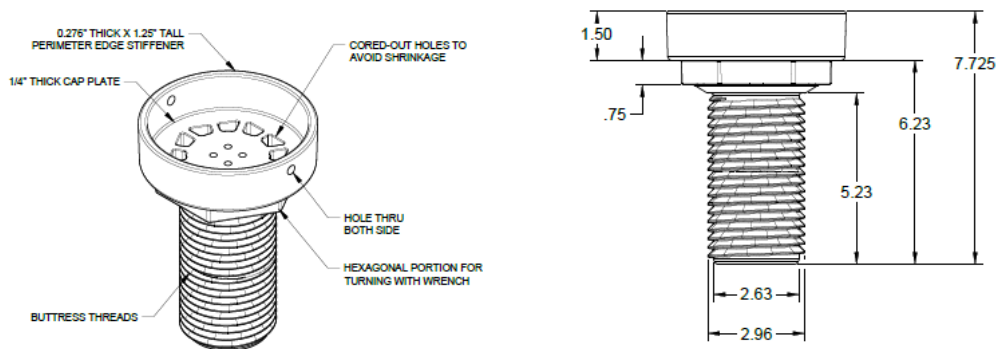

FIGURE 4—ORIGINAL EVERJACK CAP-BOLT COMPONENT

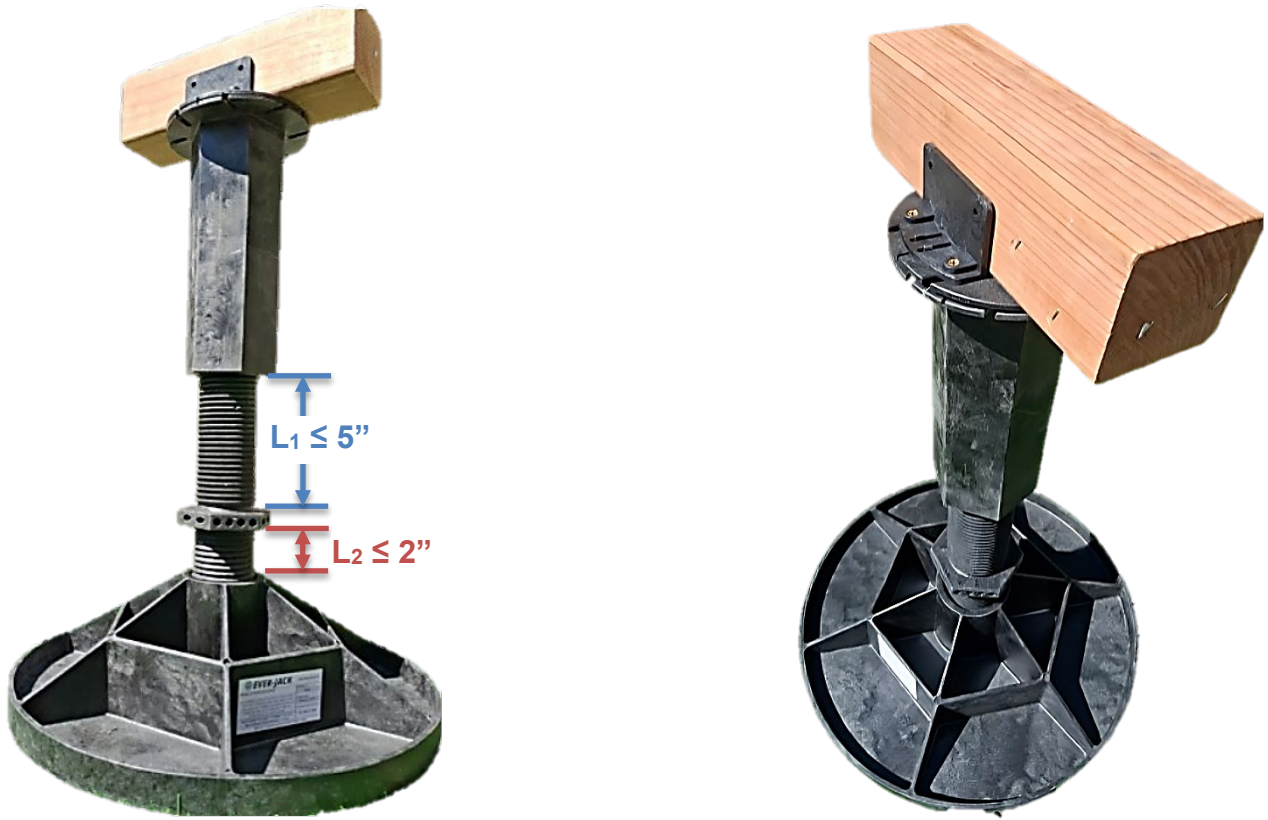

FIGURE 5 — ALL-IN-1 EVERJACK ASSEMBLY

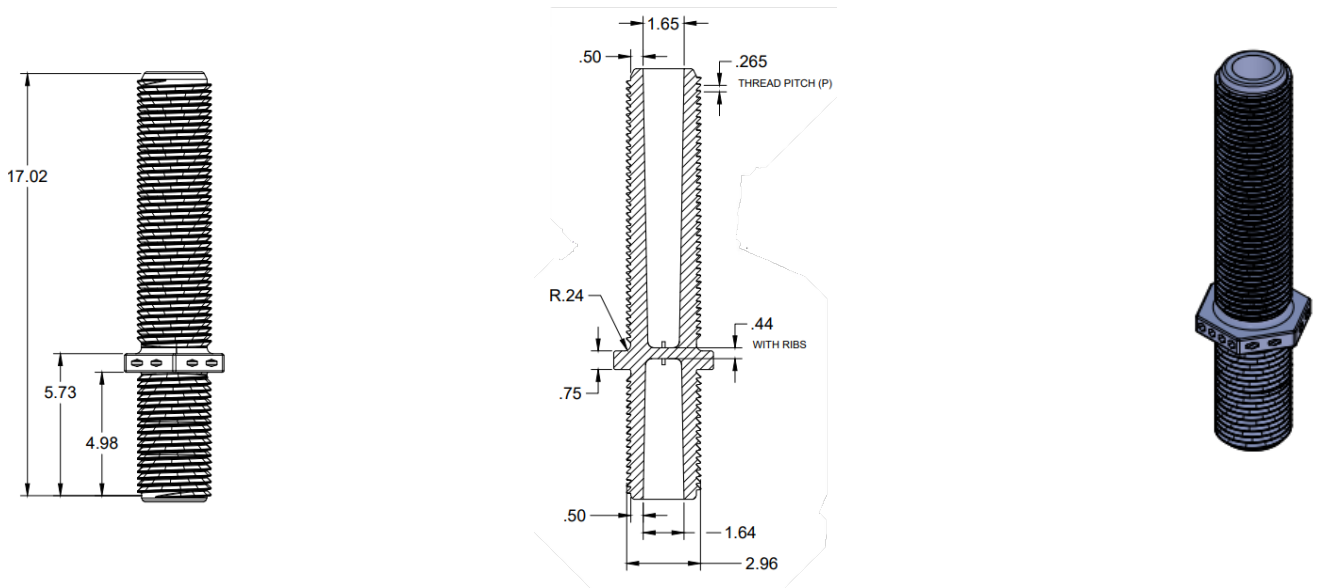

FIGURE 6 — ALL-IN-1 EVERJACK CAP-BOLT COMPONENT

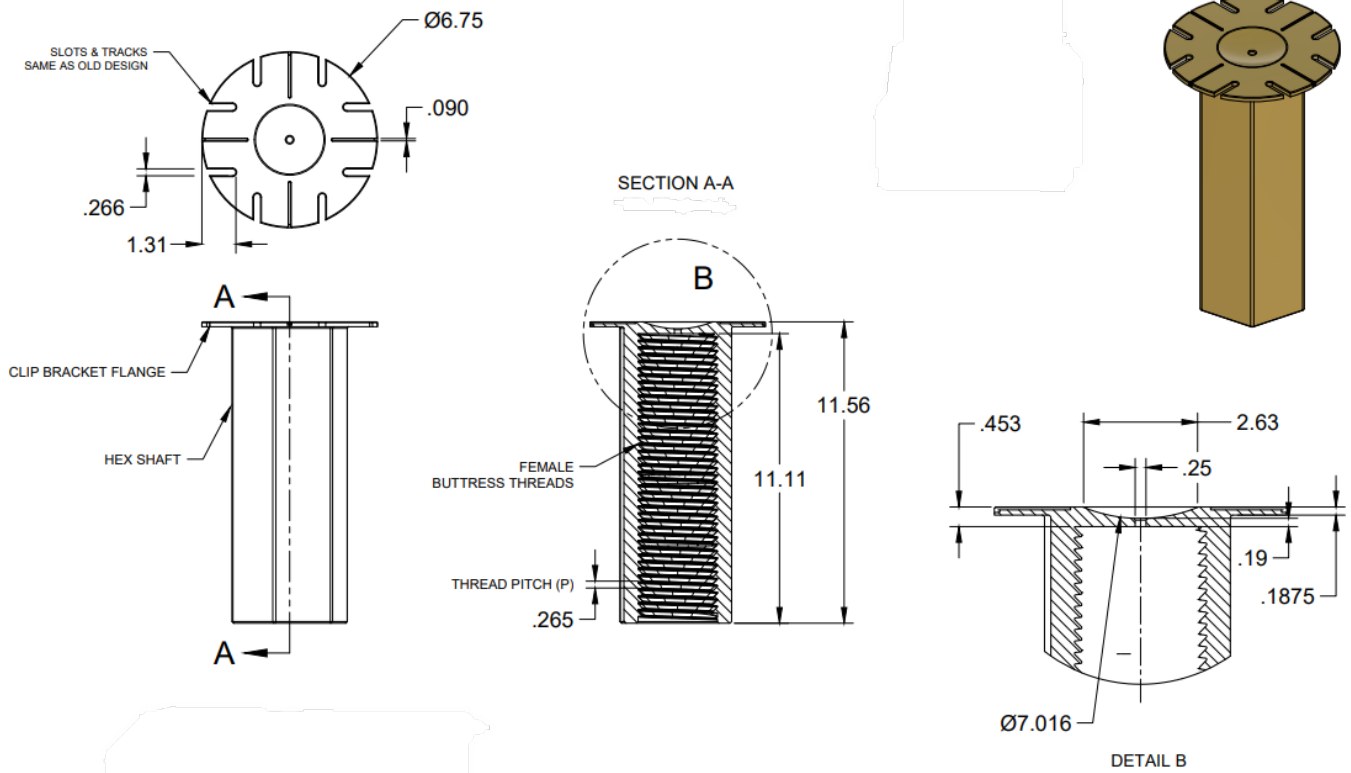

FIGURE 7 — ALL-IN-1 EVERJACK HEX SHAFT EXTENDER COMPONENT

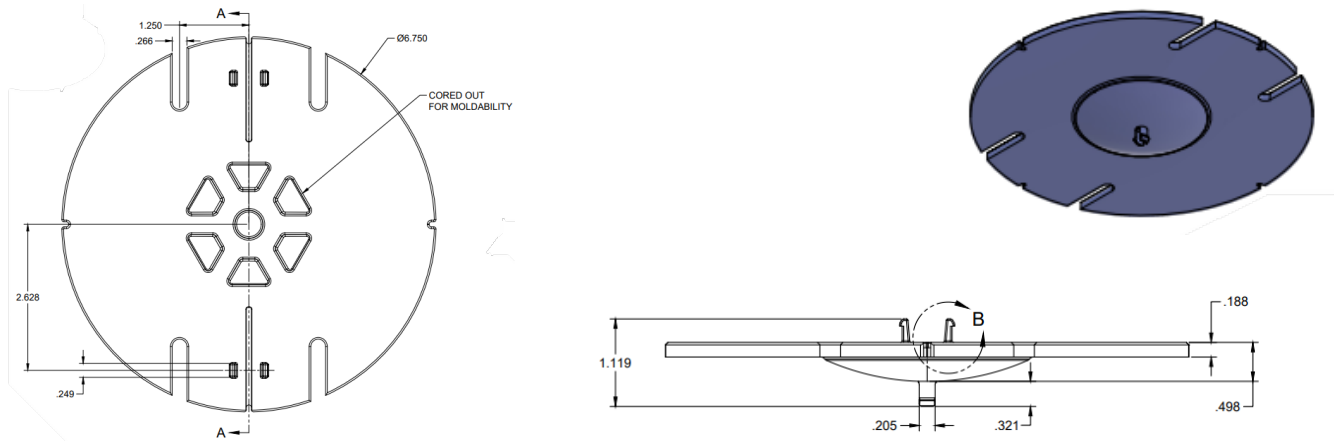

FIGURE 8 — ALL-IN-1 EVERJACK ROTATING PLATE COMPONENT

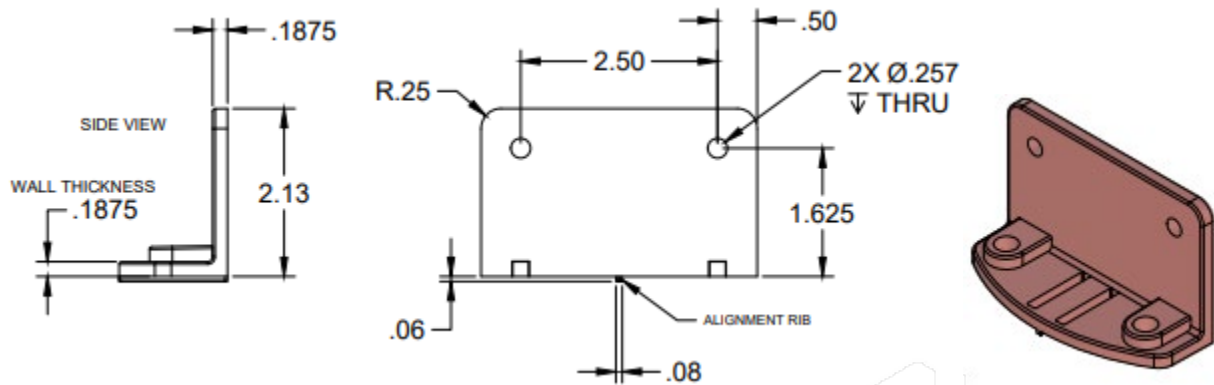

FIGURE 9 — ALL-IN-1 EVERJACK CLIP BRACKET COMPONENT